

Department of Electrical Engineering

University of Arkansas



ELEG3923 Microprocessor LCD Display

Dr. Jingxian Wu

wuj@uark.edu

LCD

- **LCD display**

- Model number: DMC-20481
- Manufacturer: Optrex (one of the largest manufacturer of LCD)
- 16 pins, we only use pins 1 ~ 14
 - Vcc: 5V, Vss: ground, Vee: ground (control display constrast)
 - E=1: enable; E=0:disable
 - R/W=1: read, R/W=0: write
 - RS=0: read or write command
RS=1: read or write data

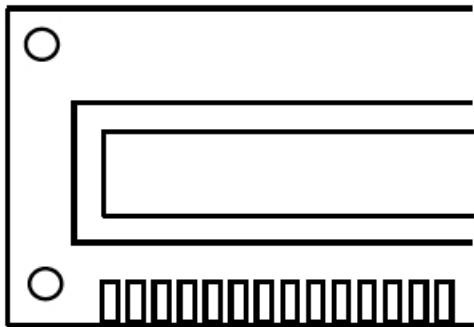

Pin	Symbol	I/O	Description
1	V _{SS}	--	Ground
2	V _{CC}	--	+5V power supply
3	V _{EE}	--	Power supply to control contrast
4	RS	I	RS = 0 to select command register, RS = 1 to select data register
5	R/W	I	R/W = 0 for write, R/W = 1 for read
6	E	I/O	Enable
7	DB0	I/O	The 8-bit data bus
8	DB1	I/O	The 8-bit data bus
9	DB2	I/O	The 8-bit data bus
10	DB3	I/O	The 8-bit data bus
11	DB4	I/O	The 8-bit data bus
12	DB5	I/O	The 8-bit data bus
13	DB6	I/O	The 8-bit data bus
14	DB7	I/O	The 8-bit data bus

LCD

- **Connection to 8051**

- In our lab the connection is slightly different

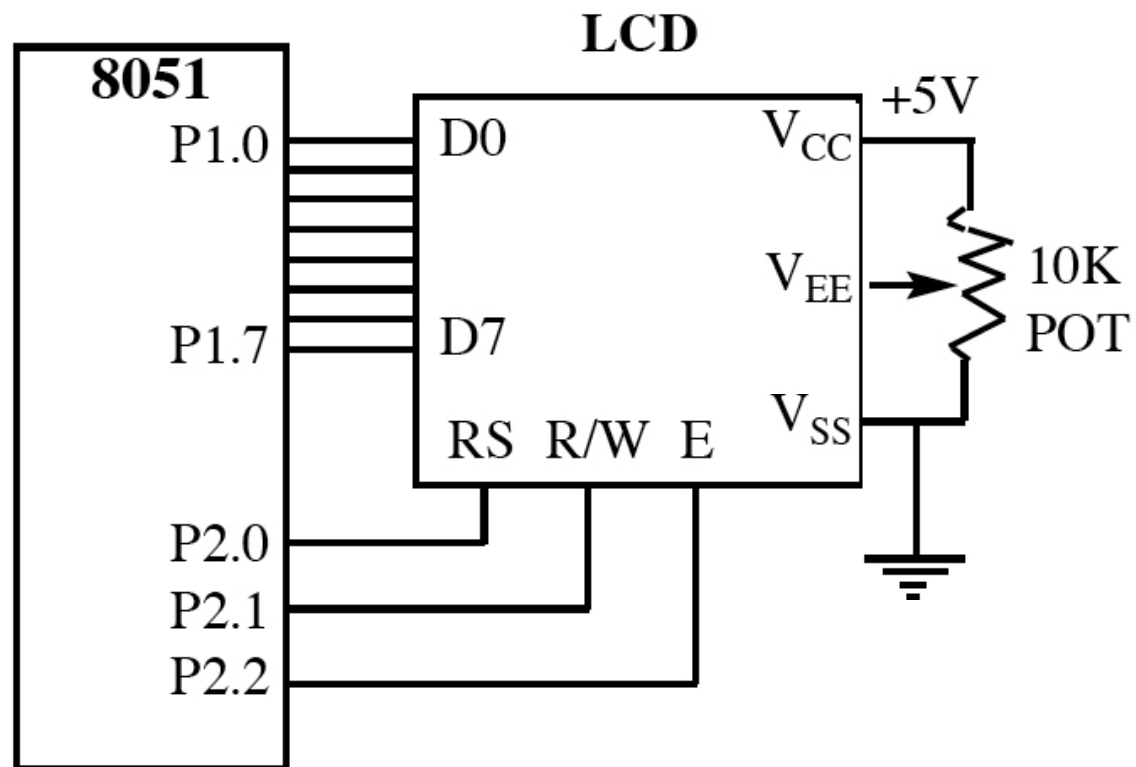

LCD

- **Operations**

- We can either read/write command or data to LCD
 - Command: e.g. clear screen, return home, decrement cursor... (P.359, Table 12-4)
 - Data: the ASCII code to be displayed

- **Example: write command to LCD**

- Use command to clear LCD display

```
RS BIT P3.2
```

```
RW BIT P3.3
```

```
EN BIT P3.4
```

```
MOV A, #01H          ; 01H: clear screen, command to be written to LCD
```

```
CLR RW              ; RW = 0: write to LCD
```

```
CLR RS              ; RS = 0: write command
```

```
MOV P1, A
```

```
SETB EN            ; a high pulse with width at least 450 ns
```

```
ACALL DELAY
```

```
CLR EN
```

LCD

- **Example: write data to LCD**

- Use command to clear LCD display

```
RS BIT P3.2
```

```
RW BIT P3.3
```

```
EN BIT P3.4
```

```
MOV A, #'A' ; 01H: clear screen, command to be written to LCD
```

```
CLR RW ; RW = 0: write to LCD
```

```
SETB RS ; RS = 1: write data
```

```
MOV P1, A
```

```
SETB EN ; a high pulse with width at least 450 ns
```

```
ACALL DELAY
```

```
CLR EN
```

- **Complete code can be found in Prog. 12-1, Prog. 12-2.**