

NCL Throughput Derivation

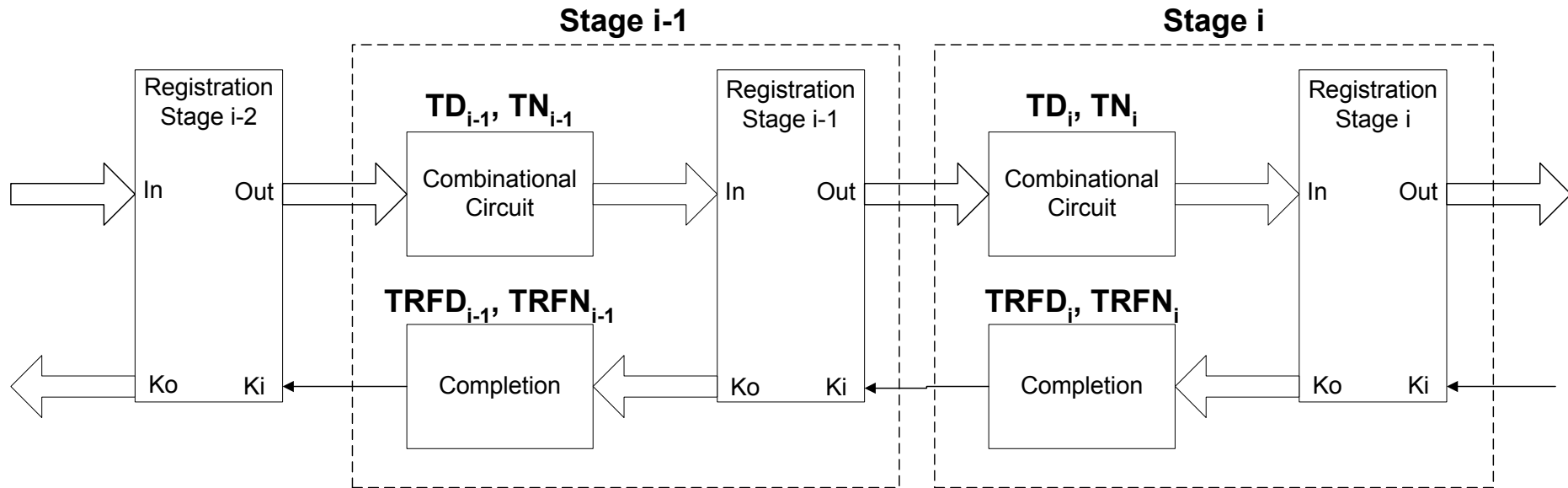

Stage	Sub-cycle	Initial State	Wavefronts								
			1	2	3	4	5	6	7	8	9
i-1	D_{i-1}		X				X				X
	N_{i-1}	X			X				X		
	RFD_{i-1}	X				X				X	
	RFN_{i-1}			X				X			
i	D_i			X				X			
	N_i	X				X				X	
	RFD_i	X					X				X
	RFN_i				X				X		

NCL Throughput Derivation (continued)

- $$T_{DDi} = \text{MAX}(TD_i, \text{TRFN}_{i-1}) + \text{MAX}(TN_{i-1}, \text{TRFN}_i) +$$
$$\text{MAX}(TN_i, \text{TRFD}_{i-1}) + \text{MAX}(TD_{i-1}, \text{TRFD}_i)$$

$$T_{DD\text{max}} = \text{TRFD}_1 + TD_1 + \text{TRFN}_1 + TN_1$$

for (i = 2 to N) loop

$$T_{DD\text{temp}} = \text{MAX}(\text{TRFD}_i + TD_i + \text{TRFN}_i + TN_i,$$
$$\text{TRFD}_{i-1} + TD_{i-1} + TD_i + \text{TRFN}_i,$$
$$\text{TRFN}_{i-1} + TN_{i-1} + TN_i + \text{TRFD}_i)$$

$$T_{DD\text{max}} = \text{MAX}(T_{DD\text{temp}}, T_{DD\text{max}})$$

end loop

$$\text{throughput} = 1 / T_{DD\text{max}}$$

NCL T_{DD} Estimation

$$T_{DD\text{max}} = 2 \times (\text{Dcomb}_1 + \text{Dcomp}_1)$$

for (i = 2 to N) loop

$$T_{DD\text{temp}} = 2 \times (\text{Dcomb}_i + \text{Dcomp}_i)$$

$$T_{DD\text{max}} = \text{MAX}(T_{DD\text{temp}}, T_{DD\text{max}})$$

end loop

Full-Word Completion

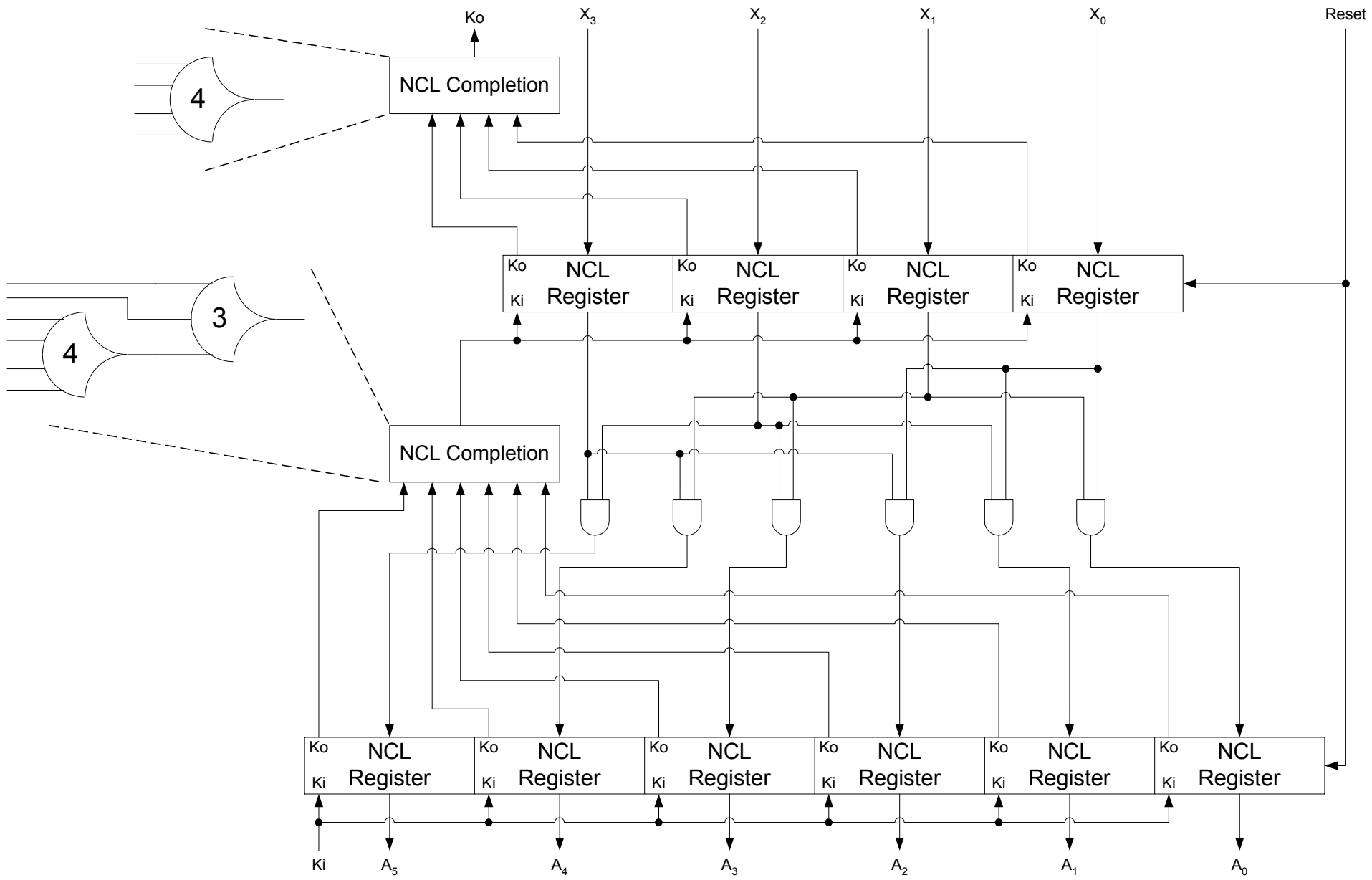

Bit-Wise Completion

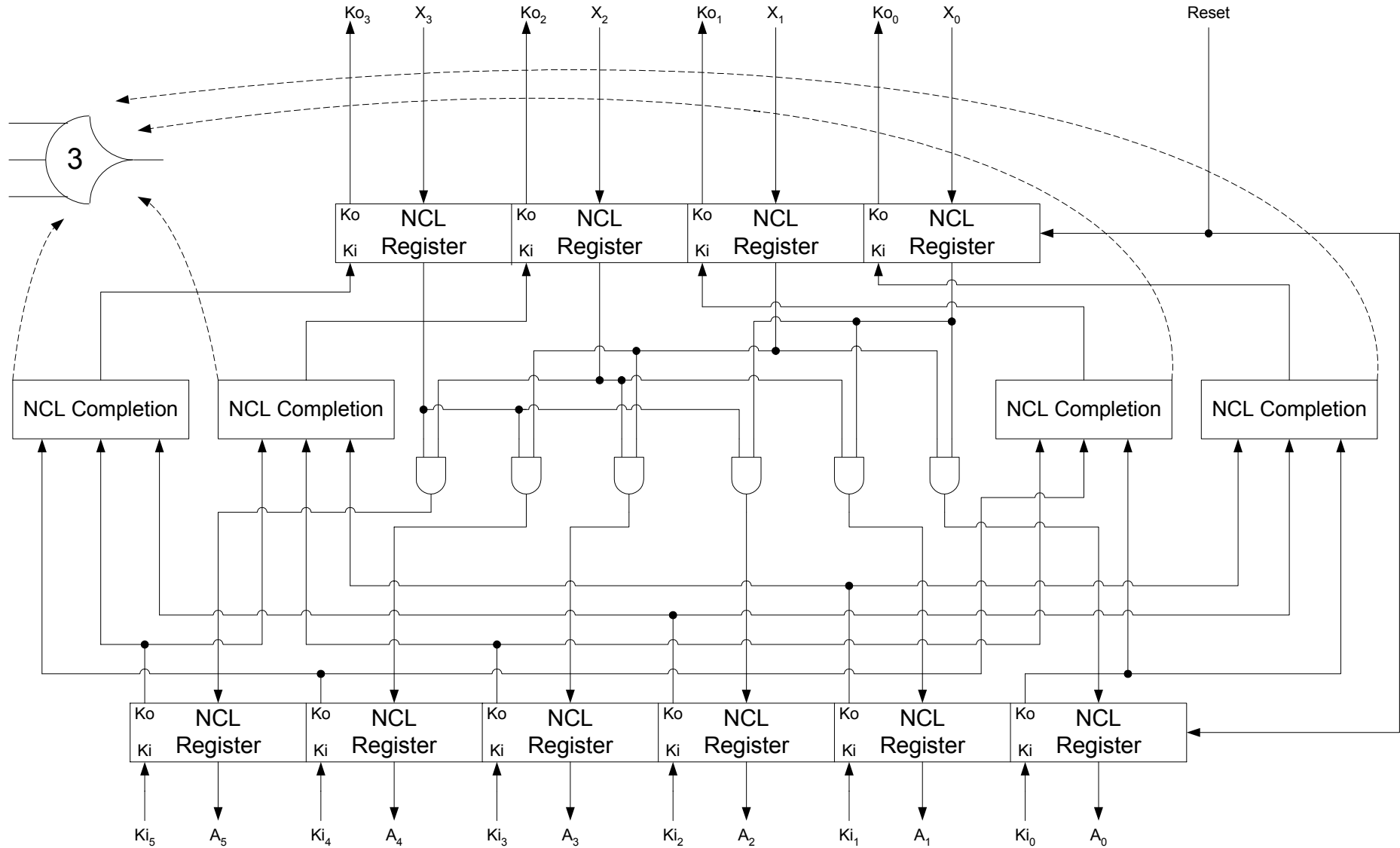

Non-Pipelined Multiplier

$T_{DD} = 24$ gate delays

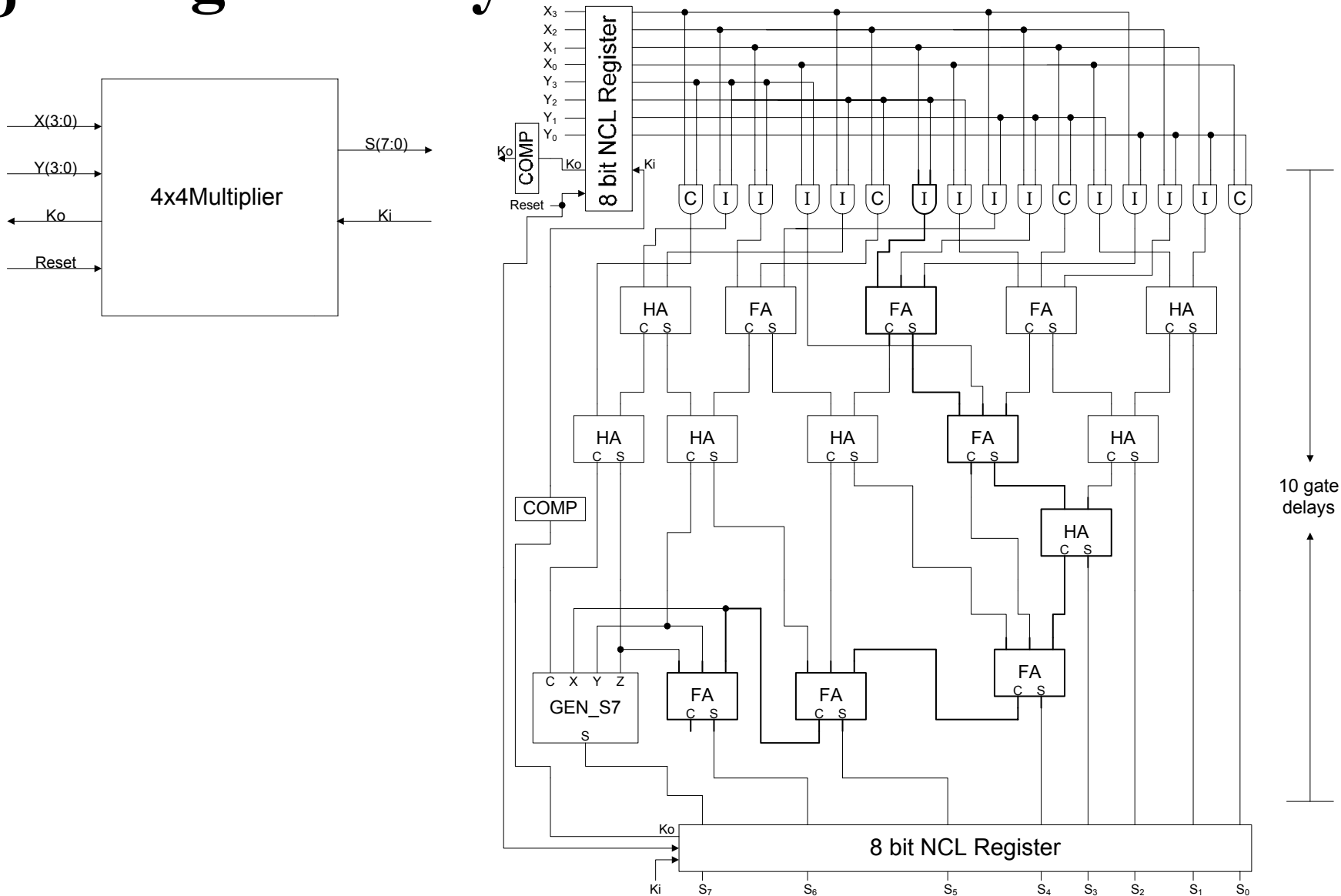

Full-Word Completion Multiplier

$$T_{DD} = 8 \text{ gate delays}$$

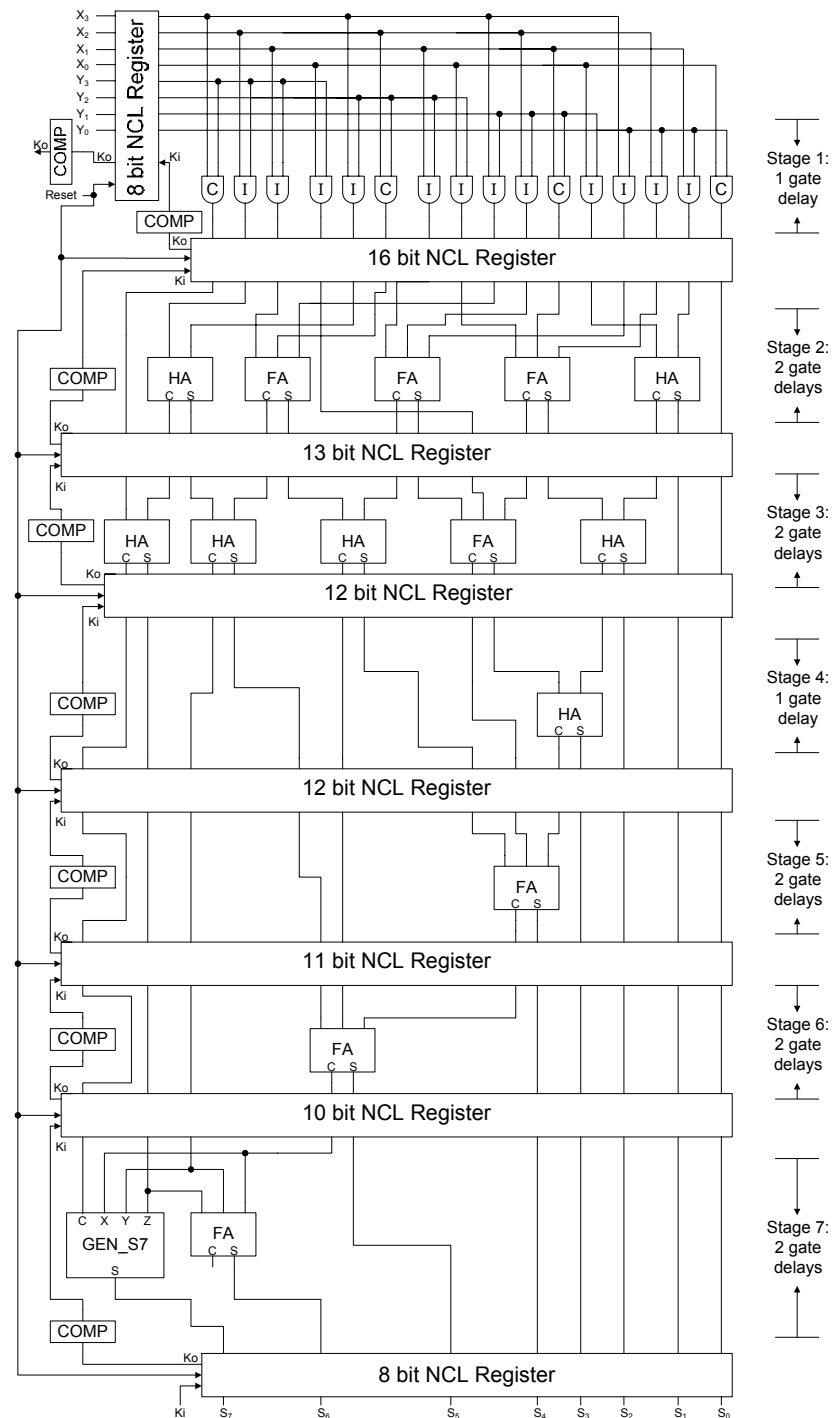

Bit-Wise Completion Multiplier

$T_{DD} = 6$ gate delays

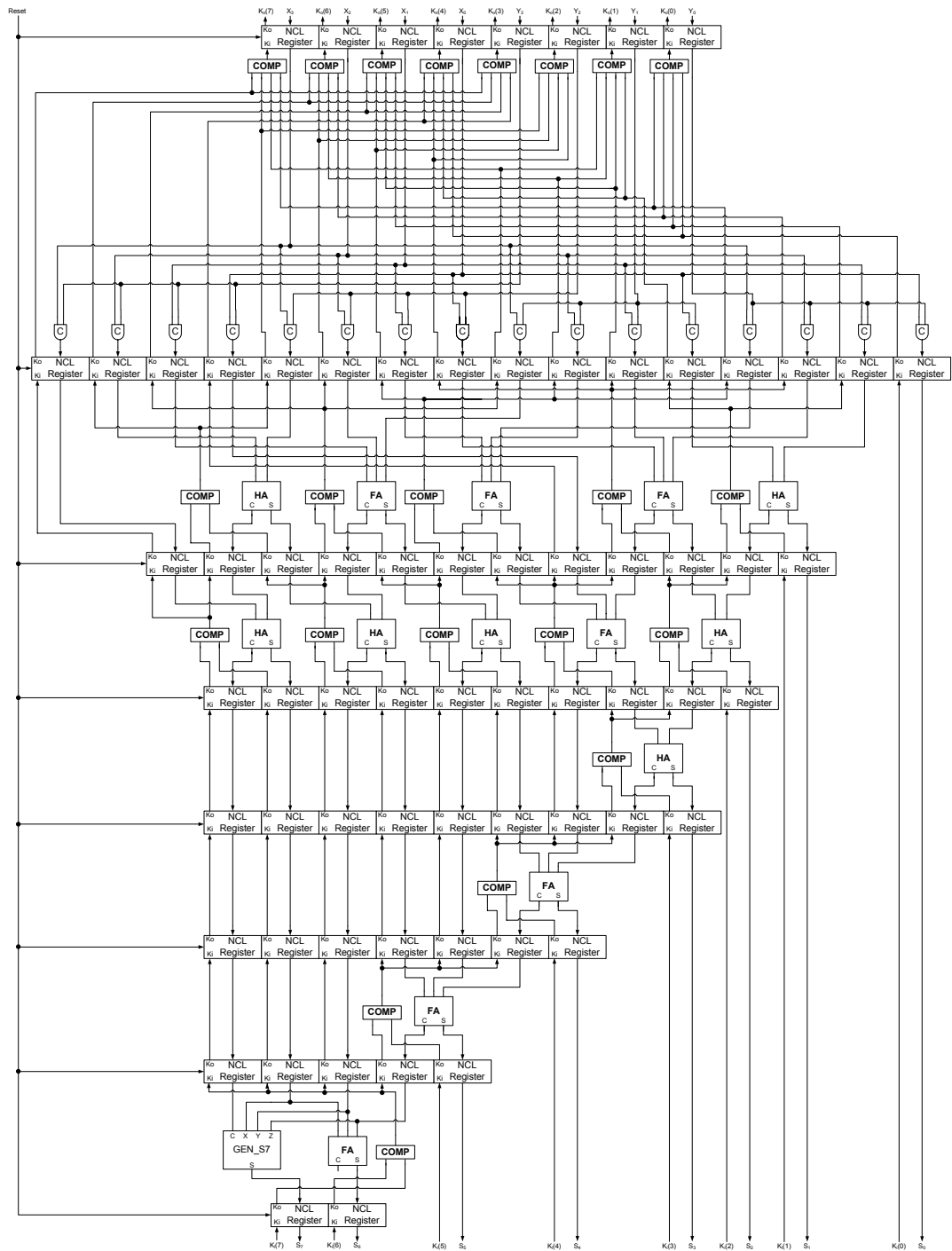

Multiplier Comparisons

Multiplier Design	Maximum Combinational Delay per Stage (gate delays)	Maximum Completion Delay per Stage (gate delays)	Predicted Throughput (gate delays)⁻¹	Simulated Throughput (ns)⁻¹
Non-Pipelined	10	2	1/24 = 0.042	0.114
Full-Word	2	2	1/8 = 0.125	0.209
Bit-Wise	2	1	1/6 = 0.167	0.257

- Throughput Optimal Design Utilizes Bit-Wise Completion
 - speedup of 1.23 over Full-Word Completion Design
 - speedup of 2.25 over Non-Pipelined Design

NCL Pipelining Algorithm

- 1) initially partition an NCL circuit into stages of *primary components*
 - a primary component is defined as a component whose inputs only consist of the circuit's inputs or outputs of components that have already been added to a previous stage
- 2) calculate the combinational and completion delay for each stage and the maximum delay for the entire pipeline, utilizing both full-word and bit-wise completion strategies
- 3) merge stages to reduce latency and area, as long as doing so does not decrease throughput

Quad-Rail Multiplier

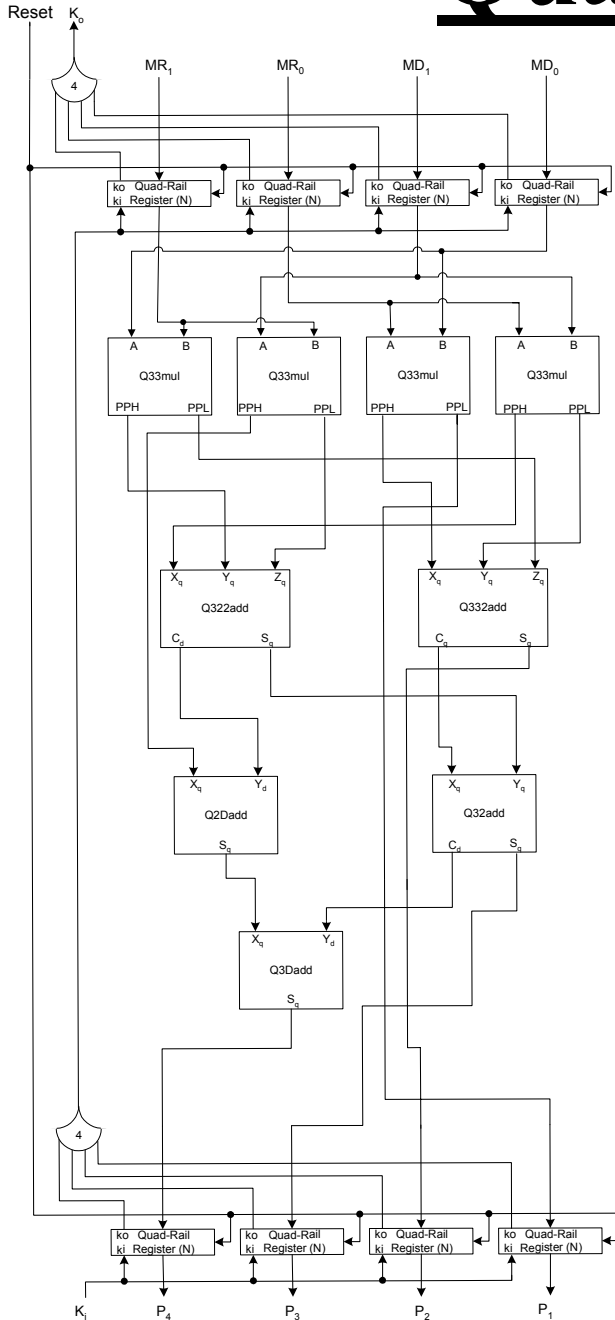

Component Type	Output Gate Delays	
	Carry / PPH	Sum / PPL
Q33mul	1	2
Q332add	3	3
Q322add	2	3
Q32add	2	2
Q2Dadd	N/A	1
Q3Dadd	N/A	1

Full-Word Completion Pipelining

Stage	D_{comb}	# Outputs	D_{comp}	delay
1	2	8	2	4
2	3	6	2	5
3	2	5	2	4
4	1	4	1	2
max_delay				5

- Stages 3 and 4 can be combined: $D_{comb} = 3$, $D_{comp} = 1$, delay = 4

Bit-Wise Completion Pipelining

Stage	D_{comb}	max_outputs	D_{comp}	delay
1	2	4	1	3
2	3	2	1	4
3	2	2	1	3
4	1	1	0	1
max_delay				4

- Stages 3 and 4 can be combined:

$$D_{comb} = 3, \text{max_outputs} = 2 \rightarrow D_{comp} = 1, \text{delay} = 4$$

NULL Cycle Reduction

- NCR applied to non-pipelined 4×4 multiplier
 - speedup of 1.61 achieved

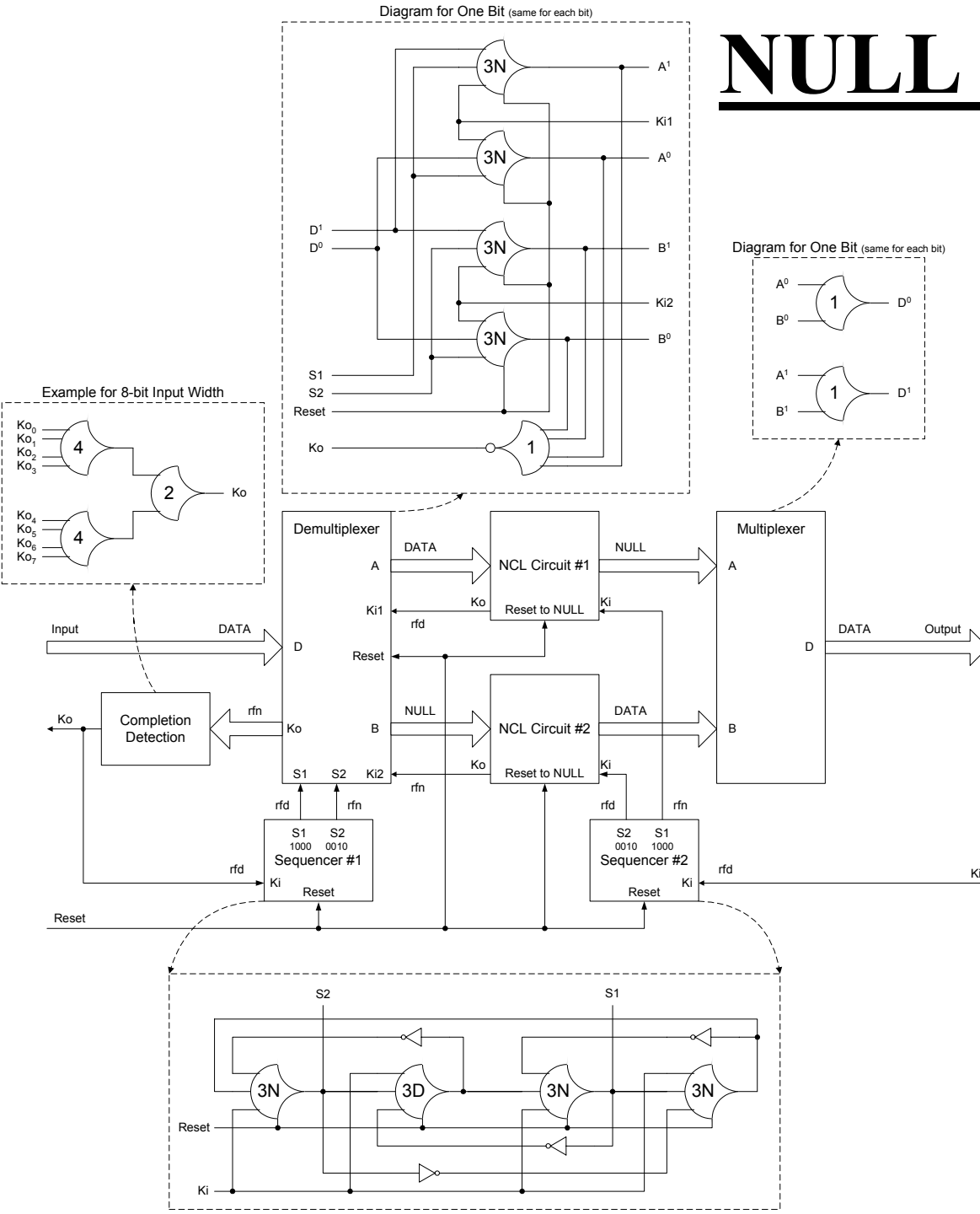

NCR Applied to a Slow Pipeline Stage

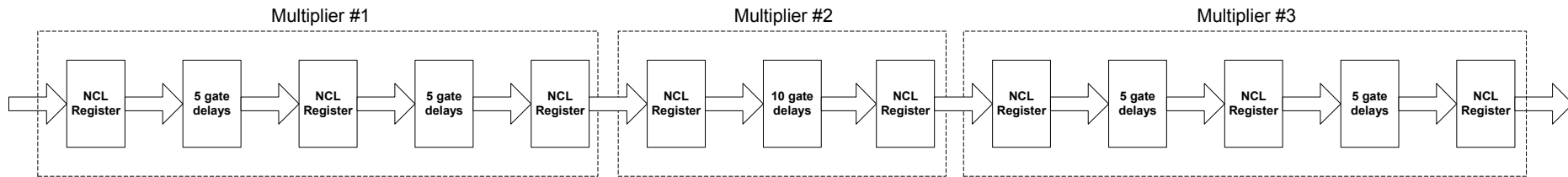

- Pipeline without NCR
 - $T_{DD} = 8.42 \text{ ns}$
- Pipeline with NCR applied to Multiplier #2
 - $T_{DD} = 6.96 \text{ ns}$
 - Speedup = 1.21

Pipelined MAC with Conditional Rounding, Scaling, and Saturation

Gate Count = 13,613

Minimum Feedback Path = 25 gate delays

$T_{DD} = 12.7 \text{ ns}$

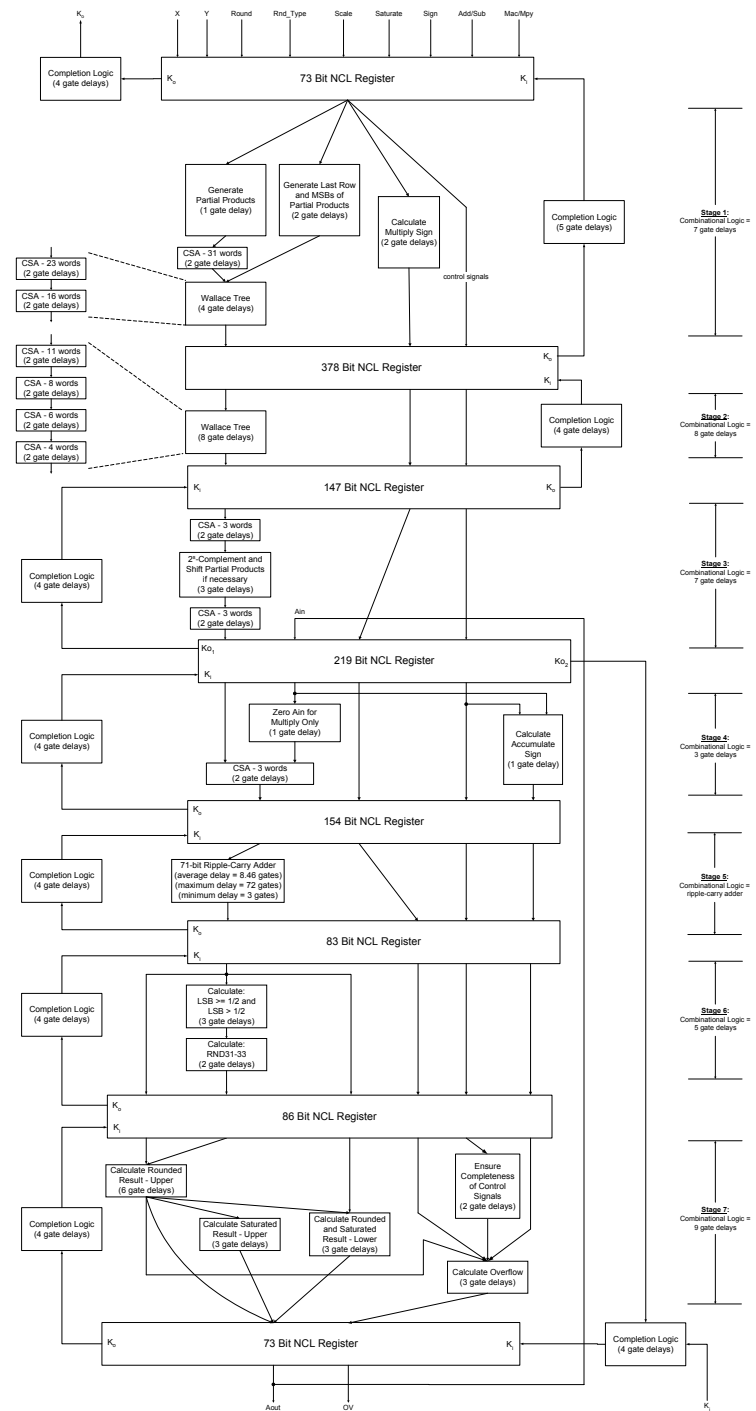

Pipelined MAC without Conditional Rounding, Scaling, and Saturation

Gate Count = 16,169

Minimum Feedback Path = 18 gate delays

$T_{DD} = 11.4 \text{ ns}$

Delay Analysis of 71-bit RCA

X	Percent $\geq X$ Gate Delays
11	21.8%
10	32.7%
9	41.4%
8	67.7%
7	91.4%
6	99.6%

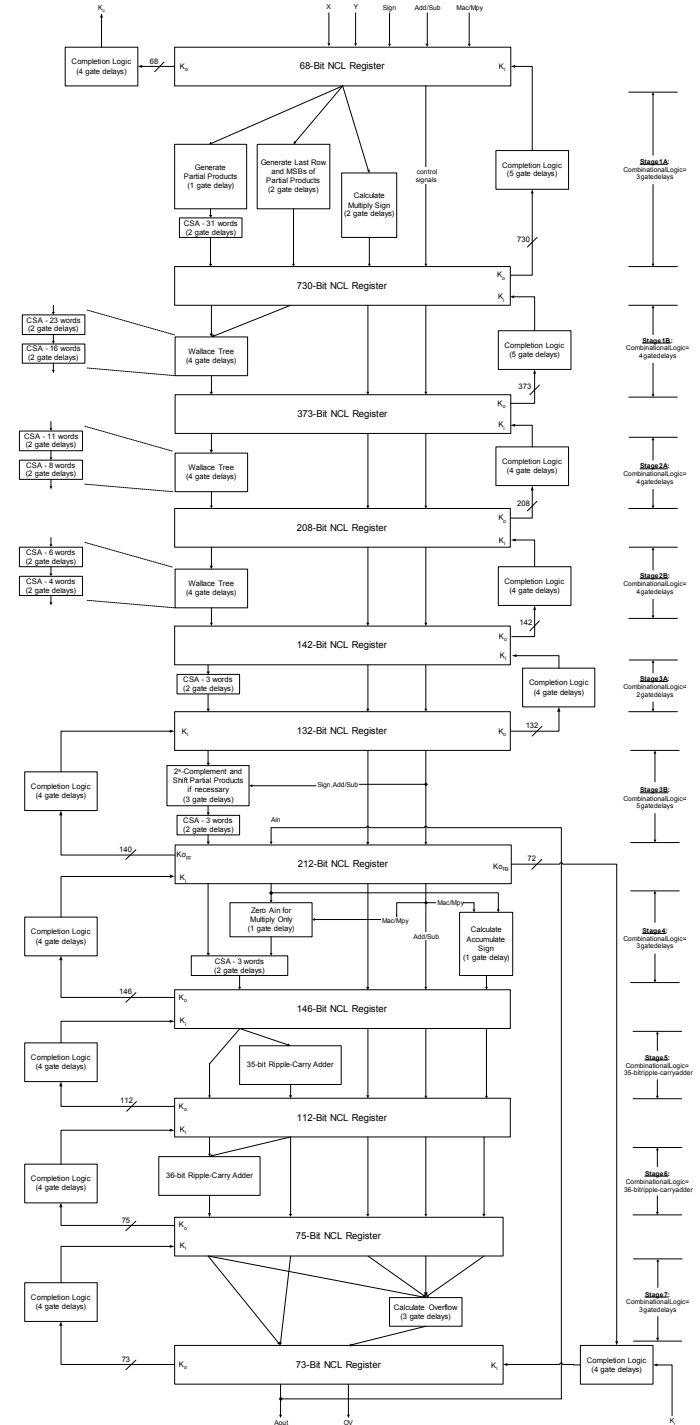

Pipelined MAC with NCR Feedback Loop

Gate Count = 22,804

$T_{DD} = 8.7 \text{ ns}$

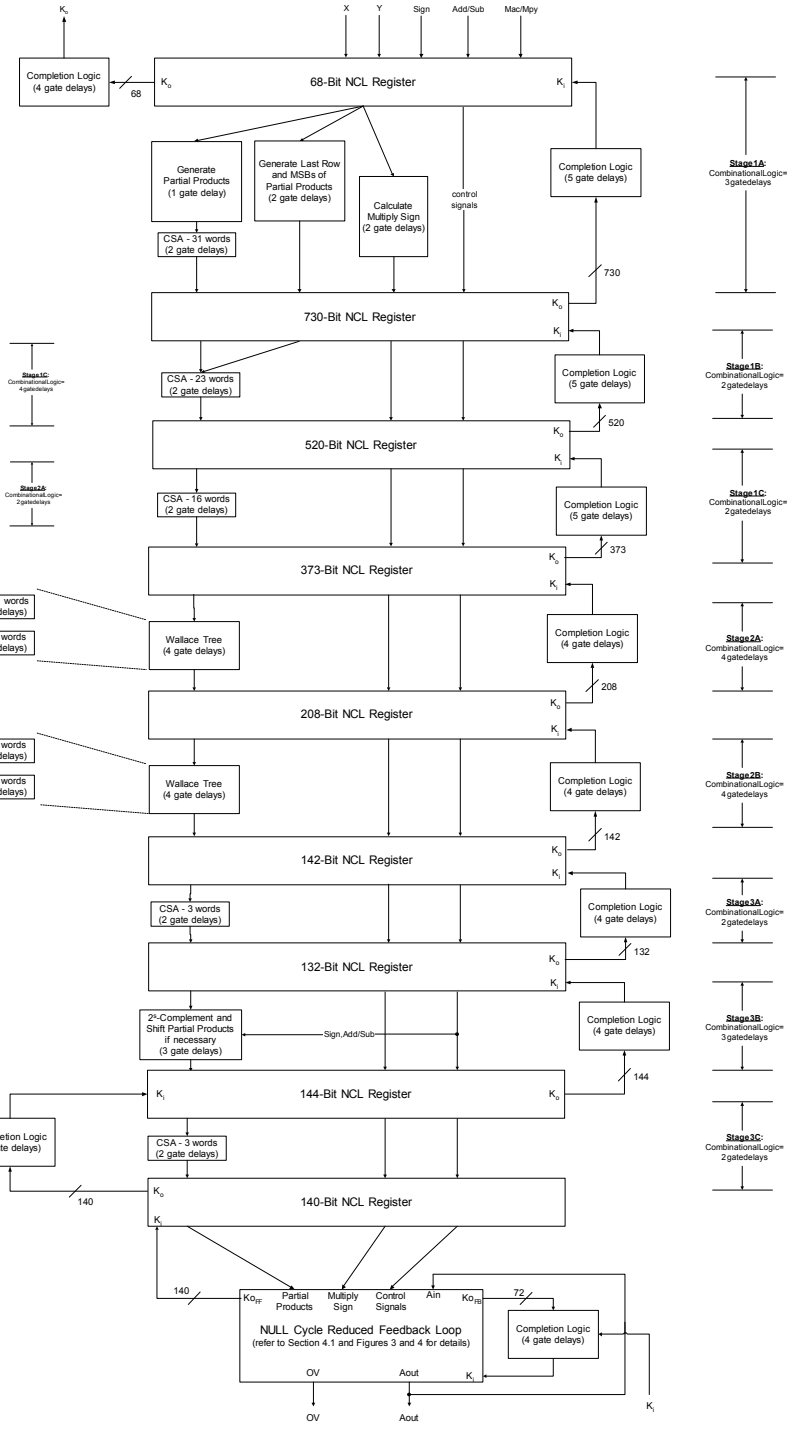
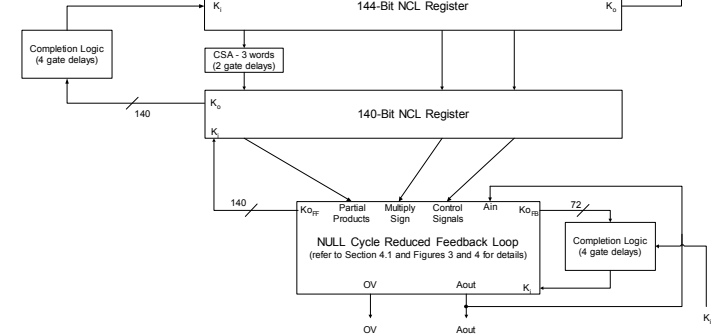
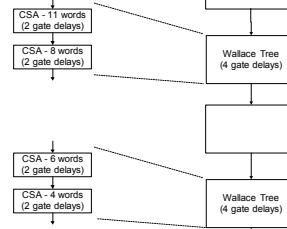
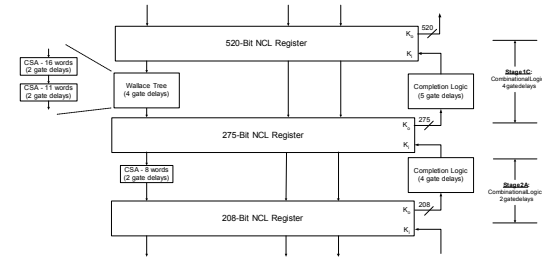
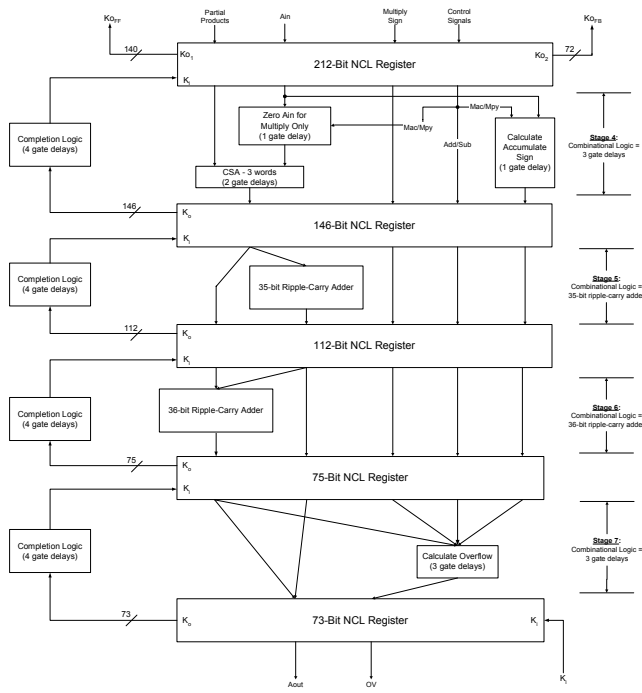

Pipelined MAC with NCR Feedback Loop and Bit-Wise Completion

Gate Count = 21,154

$T_{DD} = 8.6 \text{ ns}$

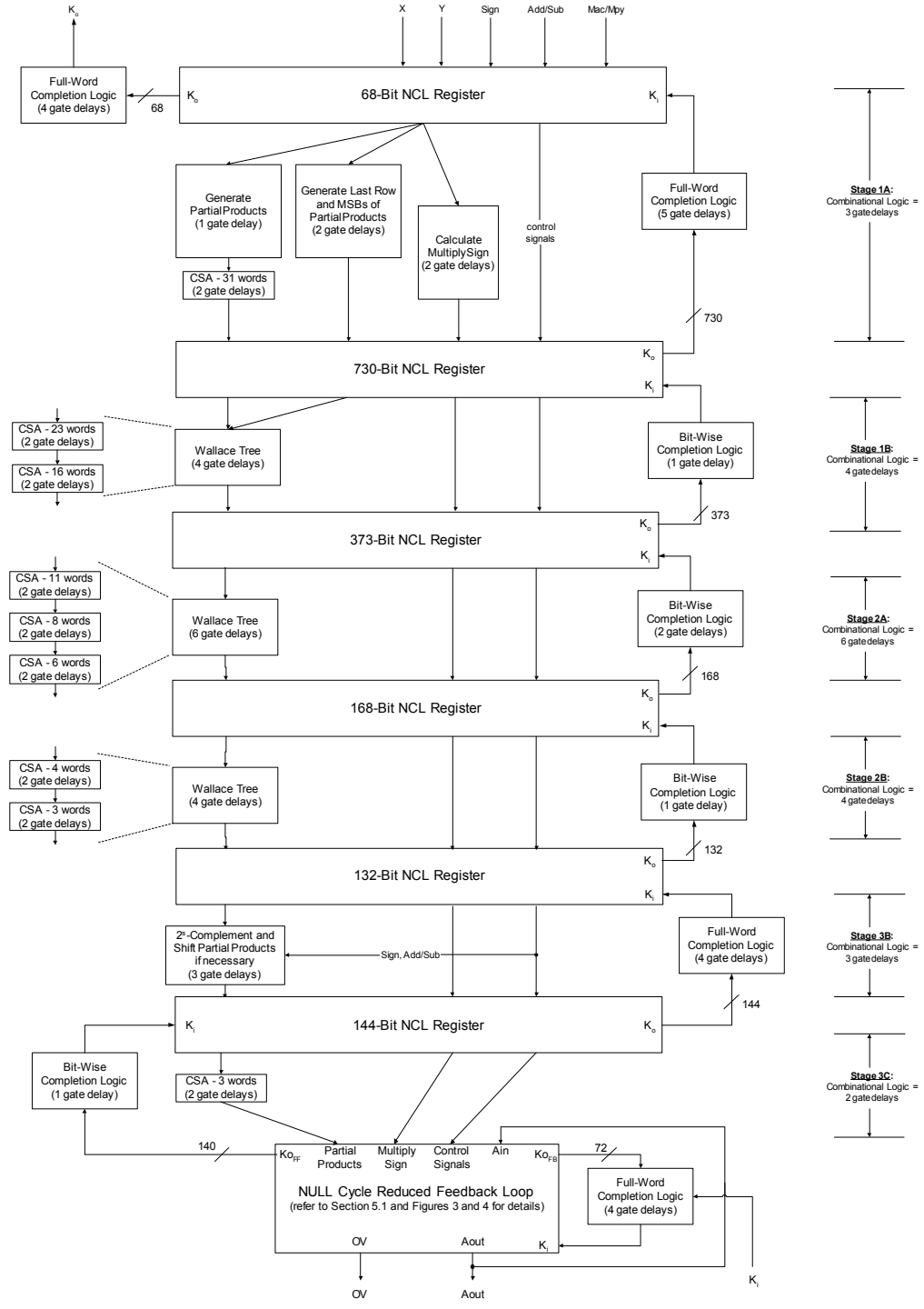

MAC Comparisons

Design	Completion Strategy	T_{DD} (ns)	Gate Count
MAC with CRSS	Full-Word	12.7	13,613
MAC without CRSS	Full-Word	11.4	16,169
NCR MAC	Full-Word	8.7	22,804
NCR MAC	Bit-Wise	8.6	21,154

- Application of NCR to throughput-limiting feedback loop yielded speedup of 1.31